

# Tube Tools

## Heat Exchangers



*Enduring Solutions*



has been conceived  
by visionary technocrats having  
more than 15 years experience in Engineering Industry.

Tristar comprises of experienced professionals with focus on the company's mission  
to offer innovative, quality tools with **Enduring Solutions** to its customers

These professionals, amongst the best, are committed to provide the highest possible quality  
tools and enduring solutions to its clients in the global market place.

**Tristar** endeavors to incorporate highest levels of technical and creative excellence in  
every project it undertakes.

**Tristar** offers a wide range of tools and equipments for every application of  
Tube Expansion and Tube Removal and a broad spectrum of services.

Thier wide product range and round the clock customer support makes

**Tristar** an ideal choice as a  
Business Partner.

# Basic Principles of Tube Expanding

Tube Expanding is the art of reducing a tube wall by compressing the O.D. of the tube against a fixed container such as rolling tubes into tube sheets, drums, ferrules or flanges. To assure a proper tube joint, the tube wall must be reduced by a pre-determined percentage. The following chart can be used for determining the correct tube wall reduction.

**This chart shows a typical 3/4" - 16 gauge tube. Before rolling this tube you should check the rolling dimensions as listed.**

- A** First determine the tube hole size.
- B** Determine the tube outside diameter.
- C** Subtract the tube outside diameter from the tube hole dimension.
- D** With a Tube Gauge, determine the inside diameter of the tube before rolling.
- E** By adding the dimension found in "D" to the clearance between the tube O.D. and the tube hole, you will then know the tube's inside diameter at metal to metal contact.
- F** Roll the tube to what you feel is a good tube joint. This example was rolled and then the I.D. of the tube was checked with a Tube Gauge.
- G** By subtracting 'E' from the rolled diameter 'F' you determine the actual amount of expansion (tube wall reduction) on the inside diameter of your tube. This can be converted to a% of wall thickness ("B minus D") .130" into the amount of roll .009.

You can use chart below to your advantage by predetermining both the % of wall reduction required and the actual inside diameter of the tube which will result in actual wall reduction. Since the amount of wall reduction greatly determines the quality of the tube joint, you should arrive at the % required for your application prior to tube rolling.

By subtracting the tube inside diameter "D" from "B", you determine actual wall thickness. This example would therefore be .130". If you then take the 7% wall reduction times the wall thickness, you arrive at .0091". Adding .0091" ("G") to .627" ("E") we get "F" the inside diameter of the tube after rolling (.636").

**Test Chart For Determining Proper Amount Of Tube Expansion**

	Tube Test Number	1	2	3
<b>A</b>	Tube sheet hole size	.757		
<b>B</b>	Tube outside diameter	.750		
<b>C</b>	Clearance (A Minus B)	.007		
<b>D</b>	Tube inside diameter	.620		
<b>E</b>	Tube inside diameter when metal to metal contact is reached (D Plus C)	.627		
<b>F</b>	Tube inside diameter after rolling	.636		
<b>G</b>	Actual amount of roll on diameter (F Minus E)	.009		

**Note:**

- 1 Take all measurements in thousands / microns.
- 2 Take "A" in middle of area to be rolled.
- 3 Take "B", "D" and "F" in same position as No.2.
- 4 Take diameters in both horizontal and vertical directions as the tube may be out of the round shape. Determine mean diameter

This technique is an excellent way to set torque rolling devices. Once you have arrived at the rolled dimension for four or five tubes, you can roll them and very simply determine if more or less wall reduction is required. Knowing how to determine wall reduction is important; however it is equally important to know the characteristics of the materials being used. We should know the proper wall reduction which would apply to each metal. A simple rule of thumb, the harder the material, the lesser the wall reduction required to obtain a tube joint. For example, you can assign these as approximate percentages of wall reduction when rolling pressure vessels;

**Tube Material:**

Copper & Cupro Nickel	8-10%
Steel, Carbon Steel & Admiralty Brass	7-8%
Stainless Steel & Titanium	4-5%

These materials and percentages can be your guideline to rolling tubes of like materials.

**Here is a summary of important factors in rolling certain alloys:**

When rolling 3003 or 4004 Alluminium you should not reduce the walls over 5%.

When rolling 6061-T Alluminium, which is one of the most popular materials used in aircraft fittings, you can reduce the wall thickness by 10 to 12% for a mechanical joint

There is a tube process called *Alonizing*, It is stated that Alonized steel combines the heat and corrosion resistant properties of the iron alluminium alloy with the strength and rigidity of steel. When rolling this tube it is extremely important to lubricate each tube end and make certain that the tube expanders are kept clean. Remove all particles of the tubing materials from the expanders to decrease tool fatigue. When rolling Alonized tubes, abrasive particles are removed from the inside diameter of the tubes and gathered in the expander. It is recommended that two expanders be used. One should be cleaned and lubricated while the other is being used.

Admiralty Brass is widely used in condensers. This material should be well lubricated. The tube wall is reduced approximately 7% to 8% for optimum tube joints. In general, only a 4% to 10% reduction in wall thickness is necessary to produce a tight tube in a serrated hole. On the other hand, reduction in excess of 15% may cause leaking, splits or flaked tubes.

Carbon Steel is used in almost every type of pressure vessel built today. Tube wall reduction should be approximately 7% to 8%. Heavy lubrication is a must. If the tube is cracking or tools show excessive wear,

tube hardness should be checked. Carbon Steel tubes should be 90 to 120 Brinell hardness for rolling. It is possible to roll tubes upto 150 Brinell; however, flaking and cracking are more likely to occur as the tube hardness increases.

When rolling Copper and Cupro Nickel, consider approximately 8-10% wall reduction to be a proper tube joint. Copper, since it is one of the softer tubes used in pressure vessels, can be easily rolled. Use plenty of lubrication because copper has an abrasive action on tube expanders.

When rolling Stainless Steel and Titanium, approximately 4 to 5% wall reduction is sufficient to produce a tight tube in a serrated hole. When rolling these alloys the entire wall reduction should be done quickly. These materials have a greater tendency to work harden; therefore, minimal or no rerolling should be done. Motor speeds should be 285 to 550 rpm.

When rolling Titanium, it is recommended to use an expander with four rolls or more. This will decrease diaphragm of a thin wall and help eliminate tube end cracking. There are, however, exceptions to the above rule.

This discussion of alloys has been related to those used in pressure vessels such as boilers, heat exchangers, and condensers. These factors would be approximately the same in a mechanical joint for industrial use. However a greater percent of wall reduction is usually considered when making a mechanical joint. Higher quality tubes are used in industrial applications.

#### Major causes of tube leaks:

Tube rolling leakage is usually caused by one of the following: under-rolling, over-rolling, improper preparation of tube sheets and differential thermal expansion. Improper expansion can lead to serious difficulties for both the manufacturer and the repair service men.

#### Under-Rolling:

Under-Rolling as the word would imply is when the tube is not expanded to fill the tube sheet hole and the proper amount of wall reduction is not obtained. It is better to under-roll than to over-roll.

#### Over-Rolling:

Over-rolling is when the expansion of the inside diameter of the tube surpasses the expansion required for the proper percentage of wall reduction for the ultimate tube joint. Over-rolling can do considerable damage to a vessel. Over-rolling will decrease the dimensions of the ligament between tubes and weakens this bridge. Once a ligament is weakened, it will cause a reaction in all ligaments surrounding that weak ligament. If we decrease the strength of the ligament the tube next to the tube being rolled will leak.

Over-rolling also causes distortion in tube sheets or drums, such as egg-shaped holes. It will also cause diametrical expansion which is the overall increase of a tube sheet or drum. Over-rolling has been known to cause a tube sheet to bow or warp to the point where the standard length tube could not be used in the vessel until the bowing or warpage is returned to the normal. This is usually corrected by placing stay rods in the vessel and pulling the tube sheets back to their original position.

#### Improper Preparation of Tube Holes:

Improper preparation of tube holes is another major cause in tube leakage. If the tube sheet or drum is gouged, it is extremely hard to expand the tube to fill

these gouges or tears without over-rolling. The smoother the tube sheet or tube hole the easier it is to roll an optimum tube joint. The ligaments and light tube walls make it more important that the finish of the tube hold be in the low micro range. Today we find many manufacturers drilling, reaming and sizing or burnishing the tube I.D.'s to get the desired microfinish for tube holes.

#### Preparation of Tube Holes:

Preparation of Tube holes in heat exchangers and condensers is as follows:

- 1 Drill and ream tube sheet holes to .007" to .010" over the outside diameter of the tube to be used.
- 2 Be certain the ligaments are sufficient to guarantee a safe and permanent tube joint.
- 3 When conditions permit, utilize a sizing or burnishing tool to further assure a good finish in the tube hole. This will also increase the tensile strength of the ligament.
- 4 The serrations or grooves to be used will determine the holding power of the tube.
- 5 It is extremely important when retubing that the grooves be cleared of all metals or any foreign material.

#### Preparation of Tube Seats:

Preparation of tube seats in drums, tube sheets, and headers are as follows:

- 1 Tube holes are normally drilled and reamed to approximately 1/32" larger than the nominal outside diameter of the tubes.
- 2 It is extremely important during this operation that there are no longitudinal scratches left in the tube seat.
- 3 In cases where out-of-roundness is extreme, pre-rolling of the tube holes is advised.
- 4 Be certain that the tube hole walls and the grooves in the tube walls are cleaned down to bare metal before tubes are inserted. Be certain all foreign material such as oil, grease, rust, or just plain dirt are removed. Special attention during this cleaning will prevent serious trouble later.

After tube holes have been prepared they are usually coated with a rust preventive compound. Before inserting any tube it is important to remove all traces of this coating. It is extremely important that great care be taken in handling the tubes for insertion in all of vessels discussed above. Be certain that the tube ends are clear of any foreign material. Be especially certain that there are no chips on the tubing which may damage the tube sheet or tube seat when the tube is placed in the vessel.

In some cases it will be necessary to force a tube hole. This should be done with extreme care. It is better to spring the tube than to try to force it with a hammer. If a tube end is kinked or damaged before rolling, the expanded end will be damaged and will result in a leaky roll joint. Prior attention to the tube ends and the tube alignment will prevent future troubles.

# Torque Controllers

## Tristar wattage setting torque controller (TWTC Series)

Tristar introduces latest state of the art torque controller unit for tube expanding based on torque control by wattage setting. The new development is superior to the conventional torque unit based on current settings and has proven reliability and accuracy. These units are available in 2 models TWTC - 230 volts & TWTC - 110 volts



### Features:

- ❑ Wattage based torque setting
- ❑ Accuracy in torque setting with a resolution of a watt, thus accurate results
- ❑ Soft start feature for all drives, reduces the sudden impact of starting on the drive unit. Life of drive unit and the Tube Expander increases
- ❑ Any drive connected is automatically recognised with a LED indication against drive model on the panel.
- ❑ Wattage range for 4 drives is automatically set when connected.
- ❑ Display of...
  - Drive wattage (Torque)
  - Set wattage (Torque)
  - Drive current
  - Line voltage
- ❑ Adjustable trip time (1 to 25 secs)
- ❑ Reverse time setting (1 to 25 secs)
- ❑ PC/Printer Compatible



### Electric Drive Units:

Drive Model		Free Speed rpm	Expansion Range		Drive Weight (lbs)
230 v	110 v		S. Steel Tube O.D.	Copper Tube O.D.	
TMP0N	TMP0L	2500	6 - 10	6 - 12	6
TMP1N	TMP1L	850	10 - 16	10 - 20	8
TMP2N	TMP2L	450	16 - 25	19 - 45	15
TMP3N	TMP3L	300	20 - 65	38 - 77	25

## SOLID State Torque Controller (TRSCP Series) available in 230/110 v

It is a digital display readout based control unit. Drive motor current setting is adjusted by the thumb wheel to deliver required precise torque.

- ❑ Eliminates over or under rolling of tubes
- ❑ Assures uniform tube joint at predetermined setting
- ❑ Increases Production
- ❑ Extends life of Tube Expander
- ❑ Enhances productivity per operator at reduced skill



# Tube Expander for Heat Exchanger and Condenser

## 'TN' Series

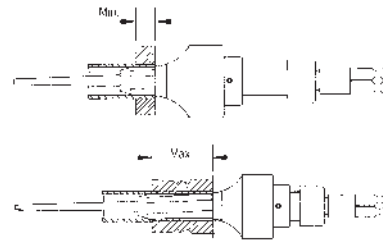

Roller Length	Adjustable Range	
	Min.	Max.
1" (25.4mm)	1/4" (6.35mm)	1" (25.4mm)

TUBE O.D. BWG	TUBE I.D.		MIN I.D. Tube Tool Enters		MAX Tool Expansion		EXPANDER With 1" (25.4 mm) long rolls		
	inch	mm	inch	mm	inch	mm	Expander Model	Roll Set Model	Mandrel Model
1/4 - 18	0.152	3.8	0.148	3.7	0.167	4.2	TA-25018	TR-20018	TM-21819
(6.35) - 19	0.166	4.2	0.160	4.0	0.180	4.5	TA-25019	TR-21920	TM-21819
- 20	0.180	4.5	0.175	4.4	0.196	4.9	TA-25020	TR-21920	TM-22021
- 21	0.186	4.7	0.180	4.5	0.202	5.1	TA-25021	TR-22124	TM-22021
- 22	0.194	4.9	0.190	4.8	0.213	5.4	TA-25022	TR-22124	TM-20022
- 23	0.200	5.0	0.195	4.9	0.216	5.5	TA-25023	TR-21920	TM-22324
- 24	0.206	5.2	0.201	5.1	0.224	5.7	TA-25024	TR-22124	TM-22324
- 28	0.222	5.6	0.217	5.4	0.243	6.1	TA-25028	TR-22830	TM-22830
- 29	0.224	5.7	0.217	5.4	0.243	6.1	TA-25028	TR-22830	TM-22830
- 30	0.226	5.7	0.217	5.4	0.243	6.1	TA-25028	TR-22830	TM-22830
3/8- 14	0.209	5.3	0.204	5.1	0.230	5.8	TA-37514	TR-21920	TM-22830
(9.53)- 15	0.231	5.8	0.225	5.6	0.265	6.6	TA-37515	TR-31516	TM-22830
- 16	0.245	6.2	0.238	6.0	0.278	7.0	TA-37516	TR-31516	TM-31617
- 17	0.259	6.5	0.253	6.4	0.293	7.4	TA-37517	TR-31720	TM-31617
- 18	0.277	7.0	0.270	6.8	0.310	7.8	TA-37518	TR-31720	TM-30018
- 19	0.291	7.3	0.285	7.1	0.325	8.1	TA-37519	TR-31720	TM-30019
- 20	0.305	7.7	0.295	7.4	0.335	8.4	TA-37520	TR-31720	TM-32021
- 21	0.311	7.9	0.305	7.5	0.345	8.6	TA-37521	TR-32122	TM-32021
- 22	0.319	8.1	0.312	7.8	0.353	8.9	TA-37522	TR-32122	TM-32224
- 23	0.325	8.2	0.318	8.1	0.363	9.2	TA-37523	TR-32324	TM-32224
- 24	0.331	8.4	0.318	8.1	0.363	9.2	TA-37523	TR-32324	TM-32224





# Tube Expander for Heat Exchanger and Condenser

## T - 900 / 1300 Series



T900 Series	Adjustable Range	
Roller Length	Min.	Max.
3/4" (19.05 mm)	1/4" (6.35 mm)	3/4" (19.05 mm)
1.1/4" (31.75 mm)	3/4" (19.05 mm)	1.1/4" (31.75 mm)

T1300 Series	Adjustable Range	
Roller Length	Min.	Max.
3/4" (19.05 mm)	3/4" (19.05 mm)	3" (76.20 mm)
1.1/4" (31.75 mm)	1.1/4" (31.75 mm)	3.1/2" (88.90 mm)

Tube O.D. BWG	Tube I.D.		Min I.D. Tube Tool Enters		Max Tool Expansion		900 Series Expander With				Mandrel Models	1300 Series Expander With				Mandrel Models
	inch	mm	inch	mm	inch	mm	3/4" (19.05 mm) rolls		1/4" (31.75 mm) rolls			1.3/4" (38 mm) rolls		1.1/4" (38 mm) rolls		
							Expander Model	Roll Set Model	Expander Model	Roll Set Model		Expander Model	Roll Set Model	Expander Model	Roll Set Model	
1/4" -18	0.152	3.8	0.151	3.8	0.173	4.4	T-921	TR-921			TM-39					
-19	0.166	4.2	0.165	4.1	0.185	4.7	T-922	TR-923			TM-39					
-20	0.180	4.5	0.175	4.4	0.200	5.1	T-923	TR-923			TM-40					
-21	0.186	4.7	0.180	4.5	0.207	5.2	T-924	TR-924			TM-40					
-22	0.194	4.9	0.190	4.8	0.216	5.5	T-925	TR-925			TM-41					
-23	0.200	5.0	0.195	4.9	0.222	5.6	T-926	TR-923			TM-41					
-24	0.206	5.2	0.201	5.1	0.230	5.8	T-927	TR-924			TM-41					
-28	0.222	5.6	0.222	5.6	0.238	6.0	T-928	TR-903			TM-928					
-29	0.224	5.7	0.222	5.6	0.238	6.0	T-928	TR-903			TM-928					
-30	0.226	5.7	0.222	5.6	0.238	6.0	T-928	TR-903			TM-928					
3/8" -14	0.209	5.3	0.201	5.1	0.232	5.8	T-927	TR-924			TM-41					
-15	0.231	5.8	0.230	5.8	0.265	6.7	T-915	TR-903			TM-42	T-1315	TR-1315	T-1316	TR-1316	TM-86
-16	0.245	6.2	0.240	6.1	0.275	6.9	T-916	TR-916			TM-36	T-1319	TR-1315	T-1319L	TR-916L	TM-86
-16	0.245	6.2	0.240	6.1	0.275	6.9			T-916L	TR-916L	TM-36L					
-17	0.259	6.5	0.255	6.4	0.289	7.3	T-918	TR-903	T-920	TR-904	TM-38	T-1317	TR-903	T-1318	TR-904	TM-88
-18	0.277	7.0	0.272	6.9	0.307	7.8	T-901	TR-903	T-902	TR-904	TM-30	T-1301	TR-903	T-1302	TR-904	TM-80
-19	0.291	7.3	0.286	7.2	0.320	8.1	T-903	TR-903	T-904	TR-904	TM-31	T-1303	TR-903	T-1304	TR-904	TM-81
-20	0.305	7.7	0.300	7.6	0.334	8.4	T-905	TR-907	T-906	TR-908	TM-32	T-1305	TR-907	T-1306	TR-908	TM-82
-21	0.311	7.9	0.306	7.7	0.340	8.6	T-907	TR-907	T-908	TR-908	TM-33	T-1307	TR-907	T-1308	TR-908	TM-83
-22	0.319	8.1	0.314	7.9	0.349	8.8	T-909	TR-909	T-910	TR-910	TM-34	T-1309	TR-909	T-1310	TR-910	TM-84
-23	0.325	8.2	0.320	8.1	0.357	9.0	T-911	TR-911	T-912	TR-912	TM-34	T-1311	TR-911	T-1312	TR-912	TM-84
-24	0.331	8.4	0.320	8.1	0.357	9.0	T-911	TR-911	T-912	TR-912	TM-34	T-1311	TR-911	T-1312	TR-912	TM-84



# Tube Expander for Heat Exchanger and Condenser

## T - 800 / 1200 Series - 3 Rollers



800 Series

T800 Series Roller Length	Adjustable Range	
	Min.	Max.
1.1/2" (38.1mm)	1/2" (12.7mm)	1.1/2" (38.1mm)
2.1/4" (57.1 mm)	1.1/4" (31.7 mm)	2.1/4" (57.1 mm)

Tube O.D. BWG	Tube I.D.		Min I.D. Tube Tool Enters		Max Tool Expansion		800 Series Expander With				Mandrel Models	1200 Series Expander With				Mandrel Models	
							1 1/2" (38 mm) rolls		2 1/4" (57.1 mm) rolls			1 1/2" (38 mm) rolls		2 1/4" (57.1 mm) rolls			
							Expander Model	Roll Set Model	Expander Model	Roll Set Model		Expander Model	Roll Set Model	Expander Model	Roll Set Model		
1/2" -14	0.334	8.4	0.324	8.23	0.374	9.50	T-797	TR-797	-	-	TM-797	T-1197	TR-797	-	-	TM-1197	
	-15	0.356	9.0	0.349	8.84	0.398	10.11	T-799	TR-1	-	-	TM-799	T-1199	TR-1	-	-	TM-1199
	-16	0.370	9.4	0.360	9.14	0.410	10.41	T-801	TR-1	-	-	TM-1	T-1201	TR-1	-	-	TM-51
	-17	0.384	9.7	0.374	9.50	0.424	10.77	T-803	TR-2	-	-	TM-1	T-1203	TR-2	-	-	TM-51
	-18	0.402	10.2	0.392	9.96	0.447	11.35	T-805	TR-3	-	-	TM-2	T-1205	TR-3	-	-	TM-52
	-20	0.430	10.9	0.406	10.80	0.461	11.7	T-805S	TR-3	-	-	TM-3	T-1205S	TR-3	-	-	TM-53
5/8"-12	0.407	10.3	0.392	9.96	0.447	11.35	T-805	TR-3	-	-	TM-2	T-1205	TR-3	-	-	TM-52	
	-13	0.435	11.0	0.425	10.79	0.480	12.19	T-807	TR-4	-	-	TM-3	T-1207	TR-4	-	-	TM-53
	-14	0.459	11.6	0.449	11.40	0.509	12.73	T-809	TR-4	TR-810	TR-4-A	TM-4	T-1209	TR-4	T-1210	TR-4-A	TM-54
	-15	0.481	12.2	0.471	11.96	0.536	13.61	T-811	TR-5	TR-812	TR-5-A	TM-5	T-1211	TR-5	T-1212	TR-5-A	TM-55
	-16	0.495	12.5	0.485	12.32	0.550	13.97	T-813	TR-6	TR-814	TR-6-A	TM-5	T-1213	TR-6	T-1214	TR-6-A	TM-55
	-17	0.509	12.9	0.499	12.67	0.564	14.32	T-815	TR-6	TR-816	TR-6-A	TM-6	T-1215	TR-6	T-1216	TR-6-A	TM-56
	-18	0.527	13.3	0.517	13.13	0.572	14.53	T-817	TR-7	TR-818	TR-7-A	TM-7	T-1217	TR-7	T-1218	TR-7-A	TM-57
	-19	0.541	13.7	0.522	13.26	0.582	14.7	T-819	TR-7	TR-820	TR-7-A	TM-6	T-1219	TR-7	T-1220	TR-7-A	TM-56
	-20	0.555	14.1	0.536	13.6	0.596	15.1	T-819S	TR-7	TR-820S	TR-7-A	TM-8	T-1219S	TR-7	T-1220S	TR-7-A	TM-58
	-21	0.561	14.2	0.536	13.6	0.596	15.1	T-819S	TR-7	TR-820S	TR-7-A	TM-8	T-1219S	TR-7	T-1220S	TR-7-A	TM-58
-22	0.569	14.4	0.536	13.6	0.596	15.1	T-819S	TR-7	TR-820S	TR-7-A	TM-8	T-1219S	TR-7	T-1220S	TR-7-A	TM-58	
3/4"-10	0.482	12.2	0.471	11.96	0.536	13.61	T-811	TR-5	TR-812	TR-5-A	TM-5	T-1211	TR-5	T-1212	TR-5-A	TM-55	
	-11	0.510	12.9	0.499	12.67	0.564	14.32	T-815	TR-6	TR-816	TR-6-A	TM-6	T-1215	TR-6	T-1216	TR-6-A	TM-56
	-12	0.532	13.5	0.522	13.26	0.582	14.70	T-819	TR-7	TR-820	TR-7-A	TM-6	T-1219	TR-7	T-1220	TR-7-A	TM-56
	-13	0.560	14.2	0.550	13.97	0.615	15.62	T-821	TR-8	TR-822	TR-8-A	TM-8	T-1221	TR-8	T-1222	TR-8-A	TM-58
	-14	0.584	14.8	0.574	14.58	0.639	16.23	T-823	TR-9	TR-824	TR-9-A	TM-8	T-1223	TR-8	T-1224	TR-8-A	TM-58
	-15	0.606	15.3	0.596	15.14	0.661	16.79	T-825	TR-10	TR-826	TR-10-A	TM-8	T-1225	TR-8	T-1226	TR-8-A	TM-58
	-16	0.620	15.7	0.605	15.37	0.685	17.40	T-827	TR-10	TR-828	TR-10-A	TM-9	T-1227	TR-10	T-1228	TR-10-A	TM-59





1200 Series

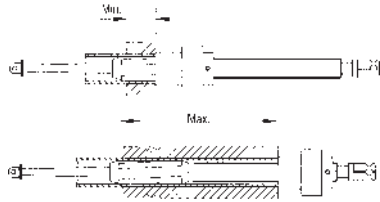

T1200 Series Roller Length	Adjustable Range		
	Reach	Min.	Max.
1.1/2" (38.1mm)	Standard	1.1/2" (38.1mm)	6" (152.4 mm)
	A	1.1/2" (38.1mm)	8" (203.1 mm)
	B	1.1/2" (38.1mm)	10" (253.8 mm)
2.1/4" (57.1 mm)	Standard	2.1/4" (57.1mm)	1.1/2" (38.1mm)
	A	2.1/4" (57.1mm)	8.3/4" (222.1mm)
	B	2.1/4" (57.1mm)	10.3/4 (323.6 mm)

Longer reaches available upon request in 2 inch (50.8 mm) increments

Tube O.D. BWG	Tube I.D.		Min I.D. Tube Tool Enters		Max Tool Expansion		800 Series Expander With				Mandrel Models	1200 Series Expander With				Mandrel Models
	inch	mm	inch	mm	inch	mm	1 1/2" (38 mm) rolls		2 1/4" (57.1 mm) rolls			1 1/2" (38 mm) rolls		2 1/4" (57.1 mm) rolls		
							Expander Model	Roll Set Model	Expander Model	Roll Set Model		Expander Model	Roll Set Model	Expander Model	Roll Set Model	
3/4"-17	0.634	16.1	0.619	15.72	0.699	17.75	T-829	TR-11	TR-830	TR-11-A	TM-9	T-1229	TR-11	T-1230	TR-11-A	TM-59
-18	0.652	16.5	0.619	15.72	0.699	17.75	T-829	TR-11	TR-830	TR-11-A	TM-9	T-1229	TR-11	T-1230	TR-11-A	TM-59
-19	0.666	16.9	0.642	16.3	0.722	18.3	T-831	TR-12	T-832	TR-12-A	TM-9	T-1231	TR-12	T-1232	TR-12-A	TM-59
-20	0.680	17.2	0.642	16.3	0.722	18.3	T-831	TR-12	T-832	TR-12-A	TM-9	T-1231	TR-12	T-1232	TR-12-A	TM-59
-21	0.686	17.4	0.642	16.3	0.722	18.3	T-831	TR-12	T-832	TR-12-A	TM-9	T-1231	TR-12	T-1232	TR-12-A	TM-59
-22	0.694	17.6	0.642	16.3	0.722	18.3	T-831	TR-12	T-832	TR-12-A	TM-9	T-1231	TR-12	T-1232	TR-12-A	TM-59
7/8"-10	0.607	15.4	0.596	15.1	0.661	16.7	T-825	TR-10	T-826	TR-10-A	TM-8	T-1225	TR-10	T-1226	TR-10-A	TM-58
-11	0.635	16.1	0.619	15.7	0.699	17.7	T-829	TR-11	T-830	TR-11-A	TM-9	T-1229	TR-11	T-1230	TR-11-A	TM-59
-12	0.657	16.6	0.642	16.3	0.722	18.3	T-831	TR-12	T-832	TR-12-A	TM-9	T-1231	TR-12	T-1232	TR-12-A	TM-59
-13	0.685	17.4	0.670	17.0	0.750	19.0	T-833	TR-13	T-834	TR-13-A	TM-10	T-1233	TR-13	T-1234	TR-13-A	TM-60
-14	0.709	18.0	0.685	17.5	0.774	19.6	T-835	TR-14	T-836	TR-14-A	TM-11	T-1235	TR-14	T-1236	TR-14-A	TM-61
-15	0.731	18.5	0.712	18.0	0.801	20.3	T-837	TR-15	T-838	TR-15-A	TM-11	T-1237	TR-15	T-1238	TR-15-A	TM-61
-16	0.745	18.9	0.726	18.4	0.815	20.7	T-839	TR-15	T-840	TR-15-A	TM-12	T-1239	TR-15	T-1240	TR-15-A	TM-62
-17	0.759	19.2	0.740	18.8	0.829	21.0	T-843	TR-16	T-844	TR-16-A	TM-12	T-1243	TR-16	T-1244	TR-16-A	TM-62
-18	0.777	19.7	0.740	18.8	0.829	21.0	T-843	TR-16	T-844	TR-16-A	TM-12	T-1243	TR-16	T-1244	TR-16-A	TM-62
1"-8	0.670	17.0	0.655	16.6	0.735	18.6	T-841	TR-13	T-842	TR-13-A	TM-9	T-1241	TR-13	T-1242	TR-13-A	TM-59
-9	0.704	17.8	0.685	17.4	0.774	19.6	T-835	TR-14	T-836	TR-14-A	TM-11	T-1235	TR-14	T-1236	TR-14-A	TM-61
-10	0.732	18.5	0.712	18.0	0.801	20.3	T-835	TR-15	T-838	TR-15-A	TM-11	T-1237	TR-15	T-1238	TR-15-A	TM-61
-11	0.760	19.3	0.740	18.8	0.829	21.0	T-843	TR-16	T-844	TR-16-A	TM-12	T-1243	TR-16	T-1244	TR-16-A	TM-62
-12	0.782	19.8	0.763	19.3	0.852	21.6	T-845	TR-17	T-846	TR-17-A	TM-12	T-1245	TR-17	T-1246	TR-17-A	TM-62
-13	0.810	20.5	0.791	20.0	0.880	22.3	T-847	TR-18	T-848	TR-18-A	TM-12	T-1247	TR-18	T-1248	TR-18-A	TM-62
-14	0.834	21.1	0.810	20.5	0.909	23.0	T-849	TR-18	T-850	TR-18-A	TM-13	T-1249	TR-18	T-1250	TR-18-A	TM-63
-15	0.856	21.7	0.837	21.2	0.936	23.7	T-851	TR-19	T-852	TR-19-A	TM-13	T-1251	TR-19	T-1252	TR-19-A	TM-63
-16	0.870	22.1	0.837	21.2	0.936	23.7	T-851	TR-19	T-852	TR-19-A	TM-13	T-1251	TR-19	T-1252	TR-19-A	TM-63



# Tube Expander for Heat Exchanger and Condenser

## T - 800 / 1200 Series - 3 Rollers



800 Series

T800 Series Roller Length	Adjustable Range	
	Min.	Max.
1.1/2" (38.1mm)	1/2" (12.7mm)	1.1/2" (38.1mm)
2.1/4" (57.1 mm)	1.1/4" (31.7 mm)	2.1/4" (57.1 mm)

Tube O.D. BWG	Tube I.D.		Min I.D. Tube Tool Enters		Max Tool Expansion		800 Series Expander With				Mandrel Models	1200 Series Expander With				Mandrel Models
							1.1/2" (38 mm) rolls		2.1/4" (57.1 mm) rolls			1.1/2" (38 mm) rolls		2.1/4" (57.1 mm) rolls		
							Expander	Roll Set	Expander	Roll Set		Expander	Roll Set	Expander	Roll Set	
							Model	Model	Model	Model		Model	Model	Model	Model	
-17	0.884	1.47)	0.865	21.9	0.964	24.4	T-855	TR-21	T-856	TR-21-A	TM-13	T-1255	TR-21	T-1256	TR-21-A	TM-63
-18	0.902	1.24)	0.865	21.9	0.964	24.4	T-855	TR-21	T-856	TR-21-A	TM-13	T-1255	TR-21	T-1256	TR-21-A	TM-63
-19	0.916	1.06)	0.865	21.9	0.964	24.4	T-855	TR-21	T-856	TR-21-A	TM-13	T-1255	TR-21	T-1256	TR-21-A	TM-63
-20	0.930	0.88)	0.865	21.9	0.964	24.4	T-855	TR-21	T-856	TR-21-A	TM-13	T-1255	TR-21	T-1256	TR-21-A	TM-63
1.1/8" -8	0.795	20.1)	0.776	19.7	0.875	22.2	T-853	TR-20	T-854	TR-20-A	TM-13	T-1253	TR-20	T-1254	TR-20-A	TM-63
-9	0.829	21.0)	0.810	20.5	0.909	(23.0)	T-849	TR-18	T-850	TR-18-A	TM-13	T-1249	TR-18	T-1250	TR-18-A	TM-63
-10	0.857	21.7)	0.837	21.2	0.936	(23.7)	T-851	TR-19	T-852	TR-19-A	TM-13	T-1251	TR-19	T-1252	TR-19-A	TM-63
-11	0.885	22.4)	0.865	21.9	0.964	24.4	T-855	TR-21	T-856	TR-21-A	TM-13	T-1255	TR-21	T-1256	TR-21-A	TM-63
-12	0.907	23.0)	0.883	22.4	0.982	24.9	T-857	TR-21	T-858	TR-21-A	TM-14	T-1257	TR-21	T-1258	TR-21-A	TM-64
-13	0.935	23.7)	0.916	23.2	1.015	25.7	T-859	TR-22	T-860	TR-22-A	TM-14	T-1259	TR-22	T-1260	TR-22-A	TM-64
-14	0.959	24.3)	0.935	23.7	1.044	26.5	T-861	TR-23	T-862	TR-23-A	TM-15	T-1261	TR-23	T-1262	TR-23-A	TM-65
15	0.981	24.9)	0.962	24.4	1.071	27.2	T-863	TR-24	T-864	TR-24-A	TM-15	T-1263	TR-24	T-1264	TR-24-A	TM-65
-16	0.995	25.2)	0.962	24.4	1.071	27.2	T-863	TR-24	T-864	TR-24-A	TM-15	T-1263	TR-24	T-1264	TR-24-A	TM-65
-17	1.009	25.6)	0.990	25.1	1.099	27.9	T-867	TR-26	T-868	TR-26-A	TM-16	T-1267	TR-26	T-1268	TR-26-A	TM-66
-18	1.027	26.0)	0.990	25.1	1.099	27.9	T-867	TR-26	T-868	TR-26-A	TM-16	T-1267	TR-26	T-1268	TR-26-A	TM-66
1.1/4" -8	0.920	23.3)	0.901	22.8	1.010	25.6	T-865	TR-25	T-866	TR-25-A	TM-15	T-1265	TR-25	T-1266	TR-25-A	TM-65
-9	0.954	24.2)	0.935	23.7	1.044	26.5	T-861	TR-23	T-862	TR-23-A	TM-15	T-1261	TR-23	T-1262	TR-23-A	TM-65
-10	0.982	24.9)	0.962	24.4	1.071	27.2	T-863	TR-24	T-864	TR-24-A	TM-15	T-1263	TR-24	T-1264	TR-24-A	TM-65
-11	1.010	25.6)	0.990	25.1	1.099	27.9	T-867	TR-26	T-868	TR-26-A	TM-16	T-1267	TR-26	T-1268	TR-26-A	TM-66
-12	1.032	26.2)	1.013	25.7	1.122	28.5	T-869	TR-27	T-870	TR-27-A	TM-16	T-1269	TR-27	T-1270	TR-27-A	TM-66
-13	1.060	26.9)	1.041	26.4	1.150	29.2	T-871	TR-28	T-872	TR-28-A	TM-17	T-1271	TR-28	T-1272	TR-28-A	TM-67
-14	1.084	27.5)	1.060	26.9	1.169	29.6	T-873	TR-29	T-874	TR-29-A	TM-17	T-1273	TR-29	T-1274	TR-29-A	TM-67
-15	1.106	28.0)	1.087	27.6	1.196	30.3	T-875	TR-30	T-876	TR-30-A	TM-17	T-1275	TR-30	T-1276	TR-30-A	TM-67
-16	1.120	28.4)	1.087	27.6	1.196	30.3	T-875	TR-30	T-876	TR-30-A	TM-17	T-1275	TR-30	T-1276	TR-30-A	TM-67



1200 Series

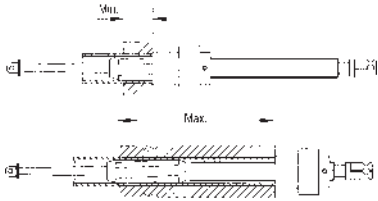

T1200 Series	Adjustable Range		
	Roller Length	Reach	Min. / Max.
1.1/2" (38.1mm)	Standard	1.1/2" (38.1mm)	6" (152.4 mm)
	A	1.1/2" (38.1mm)	8" (203.1 mm)
	B	1.1/2" (38.1mm)	10" (253.8 mm)
2.1/4" (57.1 mm)	Standard	2.1/4" (57.1mm)	1.1/2" (38.1mm)
	A	2.1/4" (57.1mm)	8.3/4" (222.1mm)
	B	2.1/4" (57.1mm)	10.3/4" (323.6 mm)

Longer reaches available upon request in 2 inch (50.8 mm) increments

Tube O.D. BWG	Tube I.D.		Min I.D. Tube Tool Enters		Max Tool Expansion		800 Series Expander With				Mandrel Models	1200 Series Expander With				Mandrel Models	
							1.1/2" (38 mm) rolls		2.1/4" (57.1 mm) rolls			1 1/2" (38 mm) rolls		2 1/4" (57.1 mm) rolls			
							Expander	Roll Set	Expander	Roll Set		Expander	Roll Set	Expander	Roll Set		
							Model	Model	Model	Model		Model	Model	Model	Model		
1.1/4"-17	1.134	28.8	1.115	28.3	1.224	31.0	T-879	TR-30	T-880	TR-30-A	TM-18	T-1279	TR-30	T-1280	TR-30-A	TM-68	
	-18	1.152	29.2	1.115	28.3	1.224	31.0	T-879	TR-30	T-880	TR-30-A	TM-18	T-1279	TR-30	T-1280	TR-30-A	TM-68
1.3/8"-8	1.045	26.5	1.026	26.0	1.135	28.8	T-877	TR-31	T-878	TR-31-A	TM-17	T-1277	TR-31	T-1278	TR-31-A	TM-67	
	-9	1.079	27.4	1.060	26.9	1.169	29.6	T-873	TR-29	T-874	TR-29-A	TM-17	T-1273	TR-29	T-1274	TR-29-A	TM-67
	-10	1.107	28.1	1.087	27.6	1.196	30.3	T-875	TR-30	T-876	TR-30-A	TM-17	T-1275	TR-30	T-1276	TR-30-A	TM-67
	-11	1.135	28.8	1.115	28.3	1.224	31.0	T-879	TR-30	T-880	TR-30-A	TM-18	T-1279	TR-30	T-1280	TR-30-A	TM-68
	-12	1.157	29.3	1.133	28.7	1.242	31.5	T-881	TR-32	T-882	TR-32-A	TM-18	T-1281	TR-32	T-1282	TR-32-A	TM-68
	-13	1.185 (30.1)		1.160	29.4	1.275	32.3	T-883	TR-33	T-884	TR-33-A	TM-19	T-1283	TR-33	T-1284	TR-33-A	TM-69
	-14	1.209 (30.7)		1.179	29.9	1.294	32.8	T-885	TR-34	T-886	TR-34-A	TM-20	T-1285	TR-34	T-1286	TR-34-A	TM-70
	-15	1.231 (31.2)		1.206	30.6	1.321	33.5	T-887	TR-35	T-888	TR-35-A	TM-20	T-1287	TR-35	T-1288	TR-35-A	TM-70
-16	1.245 (31.6)		1.206	30.6	1.321	33.5	T-887	TR-35	T-888	TR-35-A	TM-20	T-1287	TR-35	T-1288	TR-35-A	TM-70	
1.1/2"-8	1.170 (29.7)		1.145	29.0	1.260	32.0	T-889	TR-34	T-890	TR-34-A	TM-19	T-1289	TR-34	T-1290	TR-34-A	TM-69	
	-9	1.204 (30.5)		1.177	29.9	1.294	32.8	T-885	TR-34	T-886	TR-34-A	TM-20	T-1285	TR-34	T-1286	TR-34-A	TM-70
	-10	1.232 (31.2)		1.206	30.6	1.321	33.5	T-887	TR-35	T-888	TR-35-A	TM-20	T-1287	TR-35	T-1288	TR-35-A	TM-70
	-11	1.260 (32.0)		1.235	31.3	1.350	34.2	T-891	TR-36	T-892	TR-36-A	TM-20	T-1291	TR-36	T-1292	TR-36-A	TM-70
	-12	1.282 (32.5)		1.257	31.9	1.372	34.8	T-893	TR-37	T-894	TR-37-A	TM-20	T-1293	TR-37	T-1294	TR-37-A	TM-70
	-13	1.310 (33.2)		1.285	32.6	1.400	35.5	T-895	TR-37	T-896	TR-37-A	TM-21	T-1295	TR-37	T-1296	TR-37-A	TM-71
	-14	1.334 (33.8)		1.285	32.6	1.400	35.5	T-895	TR-37	T-896	TR-37-A	TM-21	T-1295	TR-37	T-1296	TR-37-A	TM-71
	-15	1.356 (34.4)		1.331	33.8	1.446	36.7	T-897	TR-38	T-898	TR-38-A	TM-21	T-1297	TR-37	T-1298	TR-37-A	TM-71
	-16	1.370 (34.8)		1.331	33.8	1.446	36.7	T-897	TR-38	T-898	TR-38-A	TM-21	T-1297	TR-37	T-1298	TR-37-A	TM-71
	-17	1.384 (35.1)		1.331	33.8	1.472	37.3	T-899	TR-38	T-900	TR-38-A	TM-22	T-1299	TR-38	T-1300	TR-38-A	TM-72
	-18	1.402 (35.6)		1.331	33.8	1.472	37.3	T-899	TR-38	T-900	TR-38-A	TM-22	T-1299	TR-38	T-1300	TR-38-A	TM-72
	-19	1.416 (35.9)		1.331	33.8	1.472	37.3	T-899	TR-38	T-900	TR-38-A	TM-22	T-1299	TR-38	T-1300	TR-38-A	TM-72
-20	1.430 (36.3)		1.331	33.8	1.472	37.3	T-899	TR-38	T-900	TR-38-A	TM-22	T-1299	TR-38	T-1300	TR-38-A	TM-72	



# Tube Expander for Heat Exchanger and Condenser

## T - 800 / 1200 Series - 5 Rollers



T800 Series Roller Length	Adjustable Range	
	Min.	Max.
1.1/2" (38.1mm)	1/2" (12.7mm)	1.1/2" (38.1mm)
2.1/4" (57.1 mm)	1.1/4" (31.7 mm)	2.1/4" (57.1 mm)

Tube O.D. BWG	Tube I.D.		Min I.D. Tube Tool Enters		Max Tool Expansion		800 Series Expander With				Mandrel Models	1200 Series Expander With				Mandrel Models	
							1.1/2" (38 mm) rolls		2.1/4" (57.1 mm) rolls			1.1/2" (38 mm) rolls		2.1/4" (57.1 mm) rolls			
							Expander	Roll Set	Expander	Roll Set		Expander	Roll Set	Expander	Roll Set		
							Model	Model	Model	Model		Model	Model	Model	Model		
5/8"-17	0.509	12.9	0.499	12.7	0.564	14.3	T-815-5	TR-4	T-816-5	TR-4A	TM-816						
	-18	0.527	13.4	0.517	13.1	0.576	14.6	T-817-5	TR-4	T-818-5	TR-4A	TM-9					
	-19	0.541	13.7	0.522	13.3	0.582	14.8	T-819-5	TR-4	T-820-5	TR-4A	TM-820					
	-20	0.555	14.1	0.536	13.6	0.596	15.1	T-819S-5	TR-4	T-820S-5	TR-4A	TM-820S					
	-21	0.561	14.2	0.536	13.6	0.596	15.1	T-819S-5	TR-4	T-820S-5	TR-4A	TM-820S					
	-22	0.569	14.5	0.536	13.6	0.596	15.1	T-819S-5	TR-4	T-820S-5	TR-4A	TM-820S					
3/4"-13	0.56	14.2	0.55	14.0	0.615	15.6	T-821-5	TR-5	T-822-5	TR-5A	TM-822						
	-14	0.584	14.8	0.574	14.6	0.629	16.0	T-823-5	TR-6	T-824-5	TR-6A	TM-824	T-1223-5	TR-6	T-1224-5	TR-6-A	TM-1224
	-15	0.606	15.4	0.59	15.0	0.661	16.8	T-825-5	TR-7	T-826-5	TR-7A	TM-826					
	-16	0.620	15.7	0.605	15.4	0.68	17.3	T-827-5	TR-7	T-828-5	TR-7A	TM-13	T-1227-5	TR-7	T-1228-5	TR-7-A	TM-63
	-17-18	0.634	16.1	0.619	15.7	0.699	17.8	T-829-5	TR-7	T-830-5	TR-7A	TM-830	T-1229-5	TR-7	T-1230-5	TR-7-A	TM-1230
	-19	0.666	16.9	0.642	16.3	0.729	18.5	T-831-5	TR-9	T-832-5	TR-9A	TM-13	T-1231-5	TR-7	T-1232-5	TR-7-A	TM-63
	-20	0.680	17.3	0.642	16.3	0.729	18.5	T-831-5	TR-9	T-832-5	TR-9A	TM-13	T-1231-5	TR-7	T-1232-5	TR-7-A	TM-63
	-21	0.686	17.4	0.642	16.3	0.729	18.5	T-831-5	TR-9	T-832-5	TR-9A	TM-13	T-1231-5	TR-7	T-1232-5	TR-7-A	TM-63
7/8"-13	0.694	17.6	0.642	16.3	0.729	18.5	T-831-5	TR-9	T-832-5	TR-9A	TM-13	T-1231-5	TR-7	T-1232-5	TR-7-A	TM-63	
	-13	0.685	17.4	0.670	17.0	0.747	19.0	T-833-5	TR-9	T-834-5	TR-9A	TM-14					
	-14	0.709	18.0	0.685	17.4	0.750	19.1	T-835-5	TR-10	T-836-5	TR-10A	TM-15					
	-16	0.745	18.9	0.726	18.4	0.800	20.3	T-839-5	TR-11	T-840-5	TR-11A	TM-840					
	-17-18	0.759	19.3	0.740	18.8	0.824	20.9	T-843-5	TR-11	T-844-5	TR-11A	TM-17					
	-19	0.791	20.1	0.763	19.4	0.851	21.6	T-845-5	TR-11	T-846-5	TR-11A	TM-18					
-20	0.805	20.4	0.763	19.4	0.851	21.6	T-845-5	TR-11	T-846-5	TR-11A	TM-18						
-21	0.811	20.6	0.763	19.4	0.851	21.6	T-845-5	TR-11	T-846-5	TR-11A	TM-18						
-22	0.819	20.8	0.763	19.4	0.851	21.6	T-845-5	TR-11	T-846-5	TR-11A	TM-18						

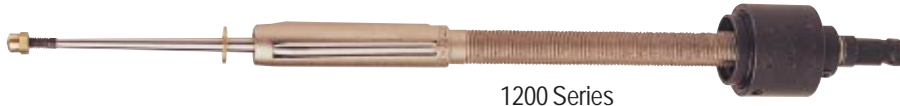

1200 Series

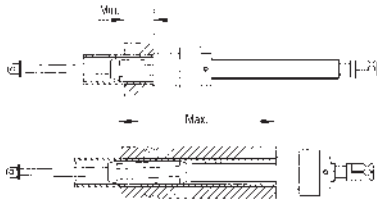

T1200 Series		Adjustable Range	
Roller Length		Reach	Min. Max.
1.1/2" (38.1mm)	Standard	1.1/2" (38.1mm)	6" (152.4 mm)
	A	1.1/2" (38.1mm)	8" (203.1 mm)
	B	1.1/2" (38.1mm)	10" (253.8 mm)
2.1/4" (57.1 mm)	Standard	2.1/4" (57.1mm)	1.1/2" (38.1mm)
	A	2.1/4" (57.1mm)	8.3/4" (222.1mm)
	B	2.1/4" (57.1mm)	10.3/4" (323.6 mm)

Longer reaches available upon request in 2 inch (50.8 mm) increments

Tube O.D. BWG	Tube I.D.		Min I.D. Tube Tool Enters		Max Tool Expansion		800 Series Expander With				Mandrel Models	1200 Series Expander With				Mandrel Models
							1 1/2" (38 mm) rolls		2 1/4" (57.1 mm) rolls			1 1/2" (38 mm) rolls		2 1/4" (57.1 mm) rolls		
							Expander Model	Roll Set Model	Expander Model	Roll Set Model		Expander Model	Roll Set Model	Expander Model	Roll Set Model	
1-12	0.782	19.9	0.763	19.4	0.852	21.6	T-845-5	TR-11	T-846-5	TR-11A	TM-18					
-13	0.810	20.6	0.791	20.1	0.880	22.4	T-847-5	TR-13	T-848-5	TR-13A	TM-18					
-14	0.834	21.2	0.810	20.6	0.879	22.3	T-849-5	TR-12	T-850-5	TR-12A	TM-850	T-1249-5	TR-12	T-1250-5	TR-12A	TM-1250
-15-16	0.856	21.7	0.837	21.3	0.936	23.8	T-851-5	TR-13	T-852-5	TR-13A	TM-852	T-1251-5	TR-13	T-1252-5	TR-13A	TM-1252
-17	0.884	22.5	0.865	22.0	0.965	24.5	T-855-5	TR-13	T-856-5	TR-13A	TM-856	T-1255-5	TR-13	T-1256-5	TR-13A	TM-1256
-18	0.902	22.9	0.865	22.0	0.965	24.5	T-855-5	TR-13	T-856-5	TR-13A	TM-856	T-1255-5	TR-13	T-1256-5	TR-13A	TM-1256
-19	0.916	23.3	0.865	22.0	0.965	24.5	T-855-5	TR-13	T-856-5	TR-13A	TM-856	T-1255-5	TR-13	T-1256-5	TR-13A	TM-1256
-20	0.930	23.6	0.865	22.0	0.965	24.5	T-855-5	TR-13	T-856-5	TR-13A	TM-856	T-1255-5	TR-13	T-1256-5	TR-13A	TM-1256
1.1/8"-12	0.907	23.0	0.883	22.4	0.997	25.3	T-857-5	TR-15	T-858-5	TR-15A	TM-21	T-1257-5	TR-15	T-1258-5	TR-15A	TM-71
-13	0.935	23.7	0.916	23.3	1.000	25.4	T-859-5	TR-16	T-860-5	TR-16A	TM-860					
-14	0.959	24.1	0.935	23.7	1.043	26.5	T-861-5	TR-17	T-862-5	TR-17A	TM-862					
1.1/4"-15	1.106	28.1	1.087	27.6	1.196	30.4	T-875-5	TR-21	T-876-5	TR-21A	TM-876					
-16	1.106	28.1	1.087	27.6	1.196	30.4	T-875-5	TR-21	T-876-5	TR-21A	TM-876					
-17	1.134	28.8	1.115	28.3	1.231	31.3	T-879-5	TR-21	T-880-5	TR-21A	TM-880					
-18	1.152	29.3	1.115	28.3	1.231	31.3	T-879-5	TR-21	T-880-5	TR-21A	TM-880					
-20	1.18	29.6	1.115	28.3	1.231	31.3	T-879-5	TR-21	T-880-5	TR-21A	TM-880					
-21	1.186	30.1	1.115	28.3	1.231	31.3	T-879-5	TR-21	T-880-5	TR-21A	TM-880					
-22	1.194	30.3	1.115	28.3	1.231	31.3	T-879-5	TR-21	T-880-5	TR-21A	TM-880					
1.3/8"-12	1.154	29.3	1.133	28.8	1.242	31.5	T-881-5	TR-21	T-882-5	TR-21A	TM-882					
-14	1.209	30.7	1.179	29.9	1.296	32.9	T-885-5	TR-23	T-886-5	TR-23A	TM-882					
1.12"-17	1.384	35.2	1.331	33.8	1.489	37.8	T-899-5	TR-29	T-900-5	TR-29A	TM-900	T-1299-5	TR-29	T-1300-5	TR-29A	TM-1299
-18	1.384	35.2	1.331	33.8	1.489	37.8	T-899-5	TR-29	T-900-5	TR-29A	TM-900	T-1299-5	TR-29	T-1300-5	TR-29A	TM-1299
-19-20	1.416	36.0	1.331	33.8	1.489	37.8	T-899-5	TR-29	T-900-5	TR-29A	TM-900	T-1299-5	TR-29	T-1300-5	TR-29A	TM-1299
-21-22	1.436	36.5	1.331	33.8	1.489	37.8	T-899-5	TR-29	T-900-5	TR-29A	TM-900	T-1299-5	TR-29	T-1300-5	TR-29A	TM-1299

# 'T-8012' Series

## Heat Exchanger and Boiler Tube Expander

- ❑ More durable components
- ❑ Extended service life
- ❑ In built thrust bearing
- ❑ Heavy duty application

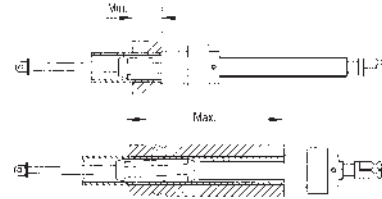

Tube O.D. inch	Bwg	Tube I.D.		Min I.D.		Max Expansion		Expander with 2.1/4" (57.15 mm) long rollers		
		inch	mm	inch	mm	inch	mm	Model No.	Mandrel	Rollers Set.
1.3/4 (44.45)	8	1.420	36.1	1.368	34.7	1.550	39.3	T 8012-1.3/4-8	TM-90	TR33-A
	10	1.482	37.6	1.420	36.0	1.607	40.8	T 8012-1.3/4-10		TR37-A
	11	1.510	38.3	1.454	36.9	1.635	41.5	T 8012-1.3/4-11		TR-42
	12	1.532	38.9	1.482	37.6	1.657	42.0	T 8012-1.3/4-12		TR-44
	13	1.560	39.6	1.510	38.3	1.685	42.7	T 8012-1.3/4-13		TR-46
	14	1.584	40.2	1.532	38.9	1.709	43.4	T 8012-1.3/4-14		TR-48
2 (50.8)	8	1.670	42.4	1.595	40.5	1.795	45.6	T 8012-2-8	TM-91	TR-48
	10	1.732	43.9	1.640	41.6	1.857	47.1	T 8012-2-10		TR-50
	11	1.760	44.7	1.670	42.4	1.885	47.8	T 8012-2-11		TR-52
	12	1.782	45.2	1.704	43.4	1.970	48.4	T 8012-2-12		TR-54
	13	1.810	45.9	1.732	43.9	1.956	49.6	T 8012-2-13-18		TR-56
	14	1.834	46.5	1.732	43.9	1.956	49.6	T 8012-2-13-18		TR-56
	15	1.856	47.1	1.732	43.9	1.956	49.6	T 8012-2-13-18		TR-56
	16	1.870	47.4	1.732	43.9	1.956	49.6	T 8012-2-13-18		TR-56
	17	1.884	47.9	1.732	43.9	1.956	49.6	T 8012-2-13-18		TR-56
	18	1.902	48.3	1.732	43.9	1.956	49.6	T 8012-2-13-18		TR-56
2.1/4	10	1.982	50.3	1.890	48.0	2.107	53.5	T8012-2.1/4-10	TM-92	TR-56
	11	2.010	51.0	1.920	48.7	2.137	54.2	T8012-2.1/4-11		TR-58
	12	2.032	51.6	1.954	49.6	2.157	54.7	T8012-2.1/4-12		TR-60
	13	2.060	52.3	1.982	50.3	2.185	55.4	T8012-2.1/4-13-16		TR-62
	14	2.084	52.9	1.982	50.3	2.185	55.4	T8012-2.1/4-13-16		TR-62
	15	2.106	53.4	1.982	50.3	2.185	55.4	T8012-2.1/4-13-16		TR-62
2.1/2"	10	2.232	56.6	2.140	54.3	2.407	61.1	T8012-2.1/2-10-12	TM-93	TR-64
	11	2.260	57.4	2.140	54.3	2.407	61.1	T8012-2.1/2-10-12		TR-64

T-8012 expanders can be supplied with 4 and 5 rollers





T8012 Series	Adjustable Range	
	Min.	Max.
Roller Length		
2.1/4" (57.1 mm)	1/2" (12.7 mm)	4" (101.6 mm)

Tube O.D. inch	Thk bwg	Tube I.D.		Min I.D.		Max Expansion		Expander with 2.1/4" (57.15 mm) long rollers		
		inch	mm	inch	mm	inch	mm	Model No.	Mandrel	Rollers Set.
2.1/2	12	2.282	57.9	2.140	54.3	2.407	61.1	T8012-2.1/2-10-12	TM-94	TR-64
	13	2.310	58.6	2.232	56.6	2.450	62.2	T8012-2.1/2-13-18		TR-64
	14	2.334	59.2	2.232	56.6	2.450	62.2	T8012-2.1/2-13-18		TR-64
	15	2.356	59.8	2.232	56.6	2.450	62.2	T8012-2.1/2-13-18		TR-64
	16	2.370	60.1	2.232	56.6	2.450	62.2	T8012-2.1/2-13-18		TR-64
	17	2.384	60.6	2.232	56.6	2.450	62.2	T8012-2.1/2-13-18		TR-64
	18	2.402	61.0	2.232	56.6	2.450	62.2	T8012-2.1/2-13-18		TR-64
	2.3/4	10	2.482	63.0	2.390	60.7	2.702	68.6	T8012-2.3/4-10-16	TM-96
11		2.510	63.7	2.390	60.7	2.702	68.6	T8012-2.3/4-10-16		TR-66
12		2.532	64.3	2.390	60.7	2.702	68.6	T8012-2.3/4-10-16		TR-66
13		2.560	65.0	2.390	60.7	2.702	68.6	T8012-2.3/4-10-16		TR-66
14		2.584	65.6	2.390	60.7	2.702	68.6	T8012-2.3/4-10-16		TR-66
15		2.606	66.1	2.390	60.7	2.702	68.6	T8012-2.3/4-10-16		TR-66
16		2.620	66.6	2.390	60.7	2.702	68.6	T8012-2.3/4-10-16		TR-66
3		8	2.670	67.8	2.560	65.0	2.829	71.8	T8012-3-8-9	TM-97
	9	2.701	68.6	2.560	65.0	2.829	71.8	T8012-3-8-9		TR-67
	10	2.732	69.3	2.640	67.0	2.952	74.9	T8012-3-10-18	TM-96	TR-67
	11	2.760	70.1	2.640	67.0	2.952	74.9	T8012-3-10-18		TR-67
	12	2.782	70.6	2.640	67.0	2.952	74.9	T8012-3-10-18		TR-67
	13	2.810	71.3	2.640	67.0	2.952	74.9	T8012-3-10-18		TR-67
	14	2.834	71.9	2.640	67.0	2.952	74.9	T8012-3-10-18		TR-67
	15	2.856	72.5	2.640	67.0	2.952	74.9	T8012-3-10-18		TR-67
	16	2.870	72.8	2.640	67.0	2.952	74.9	T8012-3-10-18		TR-67
	17	2.884	73.3	2.640	67.0	2.952	74.9	T8012-3-10-18		TR-67
18	2.902	73.7	2.640	67.0	2.952	74.9	T8012-3-10-18		TR-67	

# TR - 68 Internal Tube Cutter

It is designed to cut thick tubes. The clutch mechanism and bevel spring housed in the cutter body provides self feed positive cutting force. This eliminates operator fatigue. This design also increases the life of the cutter blade. Piloting steel balls cover the range of tube I.D. and offer easy replacement and regrinding of tool bit. Depth of cut can also be adjusted.



Tool Model No.	Spare Bit No.	Tube I.D. Range		Max Tube O.D.		Body Diameter		Drive Square Model
		mm	inch	mm	inch	mm	inch	
101215	TC - 131419	10 - 12	0.394 - 0.472	15	0.591	9.5	0.374	3/8"
111318		11 - 13	0.453 - 0.512	18	0.709	10.5	0.413	
131419		13 - 14	0.472 - 0.551	19	0.748	11.5	0.453	
131520	TC - 161925	13 - 15	0.512 - 0.591	20	0.787	12.5	0.492	1/2"
141723		14 - 17	0.551 - 0.669	23	0.906	13.5	0.531	
161925	TC - 202534	16 - 19	0.630 - 0.748	25	0.984	15.5	0.610	
182127		18 - 21	0.709 - 0.827	27	1.063	17.5	0.689	
202534		20 - 25	0.787 - 0.984	34	1.339	19.5	0.768	
253038	TC - 253038	25 - 30	0.984 - 1.181	38	1.496	24.5	0.965	
303543	TC - 405058	30 - 35	1.181 - 1.378	43	1.693	29	1.142	
354048		35 - 40	1.378 - 1.575	48	1.890	33	1.299	
405058	TC - 657583	40 - 50	1.575 - 1.969	58	2.126	38	1.296	
506068		50 - 60	1.969 - 2.362	68	2.677	48	1.890	
556573		55 - 65	2.165 - 2.559	73	2.874	53	2.087	
657583	TC - 95105113	65 - 75	2.559 - 2.953	83	3.268	63	2.480	
758593		75 - 85	2.953 - 3.326	93	3.661	73	2.894	
8595103	95105113	85 - 95	3.326 - 3.740	103	4.055	83	3.268	
95105113		95 - 105	3.740 - 4.534	113	4.449	93	3.661	

# Contipull

## Continuous tube pulling systems



- ❑ Hydraulic tube pulling systems
- ❑ Light in weight higher mobility
- ❑ Small foot print suitable for confined areas
- ❑ Higher productivity
- ❑ Low maintenance
- ❑ Silent in operation easy on operator's ears

### Power pack (Continuous tube pulling)

	TTP-50	TTP-75	TPP-50
Oil tank capacity (lts)	90	100	60
Oil	ISO 68	ISO 68	ISO 68
Weight (kg/lbs)	230 (506)	255 (561)	230 (506)
Drive	Electric	Electric	Pneumatic
Voltage	415v +/- 10%	415v +/- 10%	N. A.
Power in kw	3.7	5.5	4.9
Air consumption (cfm)	N.A	N.A	150
Air Pressure (psig)	N. A.	N. A.	90 psi
Control Voltage (v)	24	24	24

### Tube pulling guns (Continuous)

	TPG - 15	TPG - 30	TPG - 45
Pulling capacity (T @350 bar)	15	30	45
Min to Max tube O.D.	3/8" - 1"	3/8" - 1.1/2"	1" - 3"
Stub pulling capacity	- 1.1/2" O.D.	- 3" O.D.	- 4" O.D.
Pull stroke (mm)	150	150	150
Weight (kg/lbs)	25	50	61

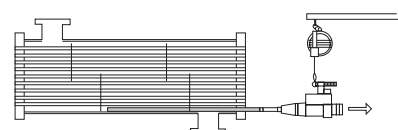
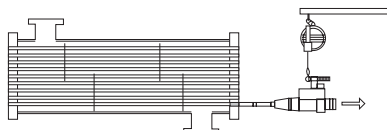
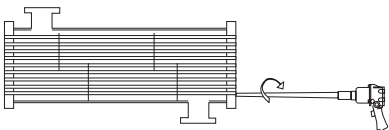

# Contipull - Consumables



MANDREL **TPM**

TUBE		MANDREL				JAW			COLLAR	
DIA	BWG	d		TPM	SQ □	TPJ 15	TPJ 30	TPJ 45	TPC 15/30	TPC 45
		mm	inch							
3/8"	17 - 19	6.5 - 7.5	0.260 - 0.295	7	5/16"	1	1		11	
	20 - 24	7.5 - 8.5	0.295 - 0.0335	8						
1/2"	14 - 16	8.5 - 9.5	0.335 - 0.375	9	3/8	2	2		14	
	17 - 18	9.5 - 10.5	0.375 - 0.415	10						
	19 - 21	10.5 - 11.5	0.415 - 0.455	11						
	24	11.5 - 12.5	0.455 - 0.495	12						
5/8"	16 - 17	12.5 - 13.5	0.495 - 0.535	13A	1/2"	3	3		18	
	19 - 21	13.5 - 14.5	0.535 - 0.570	14A						
	23 - 24	14.5 - 15.5	0.570 - 0.610	15A						
3/4"	11	12.5 - 13.5	0.495 - 0.535	13	5/8"	4	4		21	
	12 - 13	13.5 - 14.5	0.535 - 0.570	14						
	14 - 15	14.5 - 15.5	0.570 - 0.610	15						
	16 - 17	15.5 - 16.5	0.610 - 0.650	16						
	18 - 20	16.5 - 17.5	0.650 - 0.690	17						
	21 - 24	17.5 - 18.5	0.690 - 0.730	18						
7/8"	14	17.5 - 18.5	0.690 - 0.730	18S		4/A	4/A		25	
	16 - 17	18.5 - 19.5	0.730 - 0.770	19S						
	18 - 19	19.5 - 20.5	0.770 - 0.810	20S						
1"	10 - 11	18.5 - 19.5	0.730 - 0.770	19	3/4"	5	5	5	28	
	12	19.5 - 20.5	0.770 - 0.810	20						
	13 - 14	20.5 - 21.5	0.810 - 0.845	21						
	15 - 16	21.5 - 22.5	0.845 - 0.885	22						
	18	22.5 - 23.5	0.885 - 0.925	23						
	19 - 20	23.5 - 24.5	0.925 - 0.965	24						
1.1/4"	10	24.5 - 25.5	0.996 - 1.005	25	1"		7	7	34	
	11 - 12	25.5 - 26.5	1.005 - 1.045	26						
	13	26.5 - 27.5	1.045 - 1.085	27						
	14 - 15	27.5 - 28.5	1.085 - 1.125	28						
	16 - 18	28.5 - 29.5	1.125 - 1.165	29						
	19 - 22	29.5 - 30.5	1.165 - 1.200	30						
	23 - 24	30.5 - 31.5	1.200 - 1.240	31						
1.1/2"	10 - 11	31.5 - 32.5	1.240 - 1.280	32	1"	9	9	9	41	
	12 - 13	32.5 - 33.5	1.280 - 1.320	33						
	14	33.5 - 34.5	1.320 - 1.360	34						

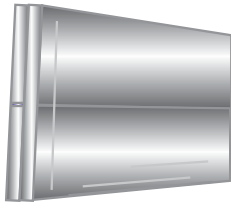

**JAW TPJ**

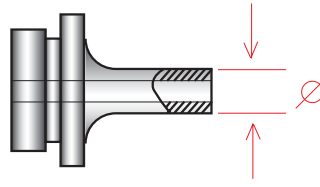

**COLLAR TPC**

TUBE		MANDREL				JAW			COLLAR $\varnothing$	
DIA	BWG	mm	inch	TPM	SQ $\square$	TPJ 15	TPJ 30	TPJ 45	TPC 15/30	TPC 45
	15 - 17	34.5 - 35.5	1.360 - 1.400	35						
	18 - 20	35.5 - 36.5	1.400 - 1.440	36						
	21 - 24	36.5 - 37.5	1.440 - 1.475	37						
1.3/4"	10 - 11	37.5 - 38.5	1.475 - 1.515	38/44	1"			11		48
	12	38.5 - 39.5	1.515 - 1.555	39/44						
	13 - 14	39.5 - 40.5	1.555 - 1.595	40/44						
	15 - 16	40.5 - 41.5	1.595 - 1.635	41/44						
	18 - 19	41.5 - 42.5	1.635 - 1.675	42/44						
	20 - 24	42.5 - 43.5	1.675 - 1.715	43/44						
2"	10	43.5 - 44.5	1.830 - 1.870	44/51	1"			13		54
	10 - 12	44.5 - 45.5	1.870 - 1.910	45/51						
	13	45.5 - 46.5	1.910 - 1.950	46/51						
	14 - 15	46.5 - 47.5	1.950 - 1.990	47/51						
	16 - 18	47.5 - 48.5	1.870 - 1.910	48/51						
	19 - 22	48.5 - 49.5	1.910 - 1.950	49/51						
2.1/4"	9 - 10	49.5 - 50.5	1.950 - 1.990	50/57	1.1/2"			14		60
	11	50.5 - 51.5	1.990 - 2.030	51/57						
	12 - 13	51.5 - 52.5	2.030 - 2.070	52/57						
2.1/2"	7	53.5 - 54.5	2.015 - 2.145	54/63	1.1/2"			16		63
	8	54.5 - 55.5	2.145 - 2.185	55/63						
	9	55.5 - 56.5	2.185 - 2.225	56/63						
	10	56.5 - 57.5	2.225 - 2.265	57/63						
3"	7	66.5 - 67.5	2.580 - 2.620	67/76	1.1/2"			17		66
	8	67.5 - 68.5	2.620 - 2.660	68/76						
	9 - 10	68.5 - 69.5	2.660 - 2.695	69/76						
	11	69.5 - 70.5	2.695 - 2.735	70/76						
3.1/2"	6	78.5 - 79.5	3.090 - 3.130	79/89	1.1/2"			18		80
	7	79.5 - 80.5	3.130 - 3.170	80/89						
	8 - 9	80.5 - 81.5	3.170 - 3.208	81/89						
	10	81.5 - 82.5	3.208 - 3.248	82/89						
4"	6	91.5 - 92.5	3.602 - 3.641	95/102				19		105
	7 - 8	92.5 - 93.5	3.641 - 3.681	93/103						
	9	93.5 - 94.5	3.681 - 3.720	94/102						
	10	94.5 - 95.5	3.720 - 3.759	95/102						



**Tool Balancer:**  
To suspend pulling gun

Model	Capacity	Wt. (kg)
E - 30	22 - 30 KG	9.5
E - 60	50 - 60 KG	12.6
E - 70	60 - 70 KG	13.2

**Sockets:**  
To drive mandrels with impact wrench

Model No.	A	B
TS - 1	3/4"	3/8"
TS - 2	3/4"	1/2"
TS - 3	3/4"	5/8"
TS - 4	3/4"	3/4"
TS - 5	3/4"	1"
TS - 6	1"	3/4"
TS - 7	1"	1"



**Impact wrench:**  
To drive mandrels

Model	A	B	Tube Dia
IMT - 1	3/4"	3/8"	upto 2"
IMT - 2	1"	1/2"	upto 3"

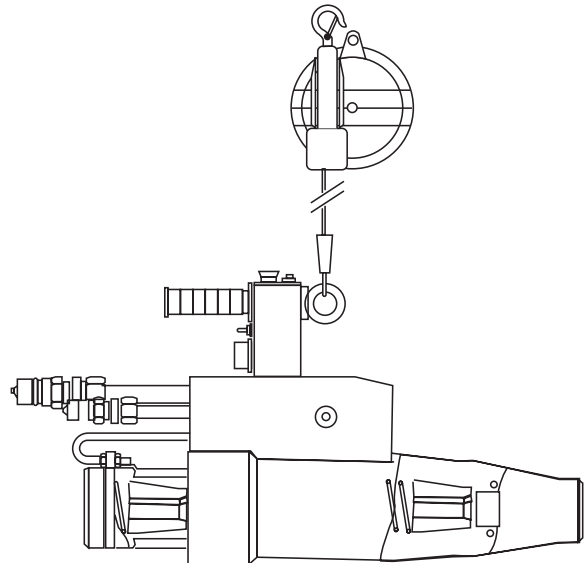

# Stub pulling system

- Compact, light weight and Portable
- Most economical
- Suitable for tube size 3/8" to 1" O.D.
- Operated with Hydraulic hand pump or Air intensifier
- Low consumables
- Auto ejection
- Pulling capacity 10 ton

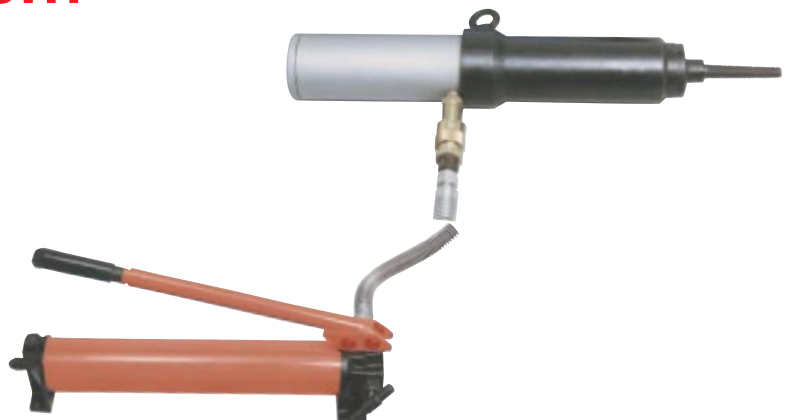



# Grooving Tool

Precision grooving of heat exchanger tubes, boiler drums and headers

**Features:**

- ❑ Accurate and Quick
- ❑ Covers wide range of bores by simply changing cutters & pilot nose
- ❑ User friendly easy to adjust length & depth of cut
- ❑ Automatic two in one design
- ❑ Form cutter and tool bit with different groove configuration can be supplied

Tool No.	Tube Sheet Hole Diameter	Maximum Groove Depth	Adjustable Range (Face to Groove)	Shank Size (Morse Taper)
1TW2MT	9.5 - 32.0	2.00	3.0 - 9.0	2
3TW3MT	16.0 - 42.0	3.50	3.0 - 14.0	3
4TW4MT	19.0 - 48.0	4.50	3.0 - 14.0	4
6TW5MT	38.0 - 130.0	7.50	3.0 - 16.0	5



**Special application of pilot in bushing**

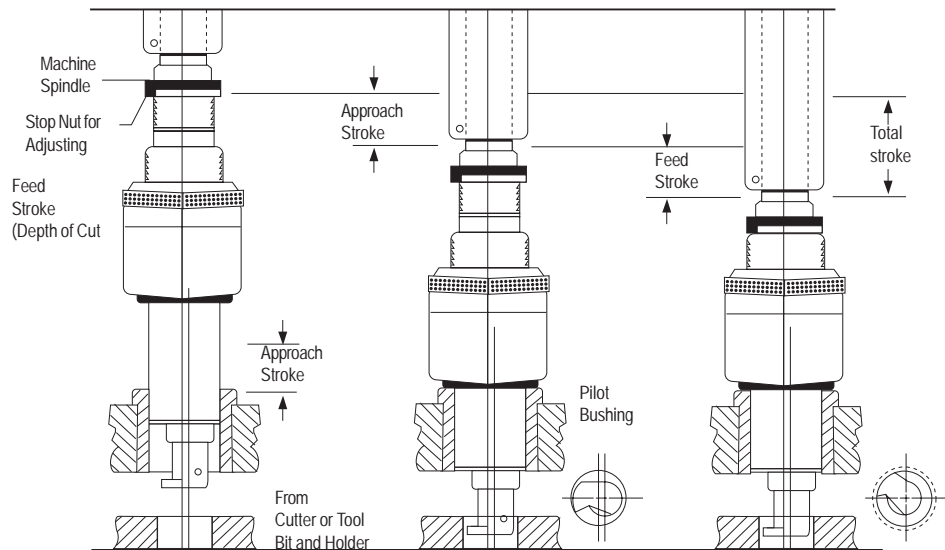

Tool in Position for Loading start of Approach Stroke

Tool in Position for Recess start of Feed Stroke

Cut Completed End of Stroke

# Tube Installation & Removal Accessories



**Serrating Tool**  
*Self centred Internal Grooving tool for predetermined size, available for 3/8" to 2.1/2" tube sheet hole sizes*



**Push Type Tube Cutter**  
*The most versatile cutter. The cutter blade depth can be adjusted. Available for 5/8" to 1" O.D. Tubes.*



**Manual Tube Puller**  
*To pull stub ends from tube sheet after internal tube cutting. Available for 5/8" to 1.1/2" O.D. tube size*

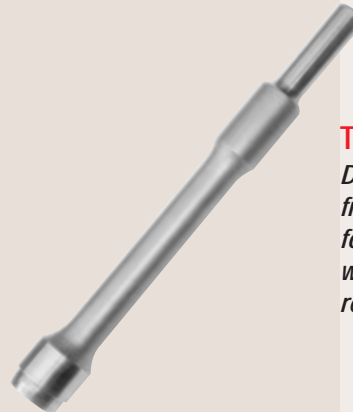

**Tube Drift**  
*Designed to remove tubes from the tube sheets, available for 1/2" to 1.1/2" O.D. Tubes with 06 shank other sizes on request*



**Tube Guide**  
*Consists of aluminium tapered nose with replaceable nylon brush used to guide tubes through tube & support plate holes. Speeds up the assembly operation & prevents tube end damage during assembly. The nylon brush fits in the tube end holding pilot firmly in place*



**Collapsing Tool**  
*Designed to collapse the tubes in the tube sheet after cutting, available for 1/2" to 1.1/2" O.D. Tubes with 06 shank other sizes on request*

Note: Also available other tools like Tube end facers, Wall reducing tools, Tube Plugs etc.

**TUBE SIZES**

BWG Wall Thickness	1	2	3	4	5	6	7	8	9	10	11	12	13	14	15	16	17	18	19	20	21	22	23	24
	0.300	0.284	0.259	0.238	0.220	0.203	0.180	0.165	0.148	0.134	0.120	0.109	0.095	0.083	0.072	0.065	0.058	0.049	0.042	0.035	0.032	0.028	0.026	0.022
Inside Diameter (inch)																								
1/4												0.032	0.060	0.084	0.106	0.120	0.134	0.152	0.166	0.180	0.186	0.194	0.200	0.206
3/8								0.045	0.079	0.107	0.135	0.157	0.185	0.209	0.231	0.245	0.259	0.277	0.291	0.305	0.311	0.319	0.325	0.331
-1/2				0.024	0.060	0.094	0.140	0.170	0.204	0.232	0.260	0.282	0.310	0.334	0.356	0.370	0.384	0.402	0.416	0.430	0.436	0.444	0.450	0.456
5/8	0.025	0.057	0.107	0.149	0.185	0.219	0.265	0.395	0.329	0.357	0.385	0.407	0.435	0.459	0.481	0.495	0.509	0.527	0.541	0.555	0.561	0.569	0.575	0.581
3/4	0.150	0.182	0.232	0.274	0.310	0.344	0.390	0.420	0.454	0.482	0.510	0.532	0.560	0.584	0.606	0.620	0.634	0.652	0.666	0.680	0.686	0.694	0.700	0.706
7/8	0.275	0.307	0.357	0.399	0.435	0.469	0.515	0.545	0.579	0.607	0.635	0.657	0.685	0.709	0.731	0.745	0.759	0.777	0.791	0.805	0.811	0.819	0.825	0.831
1	0.400	0.432	0.482	0.524	0.560	0.594	0.640	0.670	0.704	0.732	0.760	0.782	0.810	0.834	0.856	0.870	0.884	0.902	0.916	0.930	0.936	0.944	0.950	0.956
1.1/4	0.650	0.682	0.732	0.774	0.810	0.844	0.890	0.920	0.954	0.982	1.010	1.032	1.060	1.084	1.106	1.120	1.134	1.152	1.166	1.180	1.186	1.194	1.200	1.206
1.1/2	0.900	0.932	0.982	1.024	1.060	1.094	1.140	1.170	1.204	1.232	1.260	1.282	1.310	1.334	1.356	1.370	1.384	1.402	1.416	1.430	1.436	1.444	1.450	1.456
1.3/4	1.150	1.182	1.232	1.274	1.310	1.344	1.390	1.420	1.454	1.482	1.510	1.532	1.560	1.584	1.606	1.620	1.634	1.652	1.666	1.680	1.686	1.694	1.700	1.706
2	1.400	1.432	1.482	1.524	1.560	1.594	1.640	1.670	1.704	1.732	1.760	1.782	1.810	1.834	1.856	1.870	1.884	1.902	1.916	1.930	1.936	1.944	1.950	1.956
2.1/4	1.650	1.682	1.732	1.774	1.810	1.844	1.890	1.920	1.954	1.982	2.010	2.032	2.060	2.084	2.106	2.120	2.134	2.152						
2.1/2	1.900	1.932	1.982	2.024	2.060	2.094	2.140	2.170	2.204	2.232	2.260	2.282	2.310	2.334	2.356	2.370	2.384	2.402						
2.3/4	2.150	2.182	2.232	2.274	2.310	2.344	2.390	2.420	2.454	2.482	2.510	2.532	2.560	2.584	2.606	2.620	2.634	2.652						
3	2.400	2.432	2.482	2.524	2.560	2.594	2.640	2.670	2.704	2.732	2.760	2.782	2.810	2.834	2.856	2.870	2.884	2.902						

**Inside Diameter (metric)**

BWG	7.620	7.214	6.579	6.045	5.588	5.156	4.572	4.191	3.759	3.404	3.048	2.769	2.413	2.108	1.829	1.651	1.473	1.245	1.067	0.889	0.813	0.711	0.635	0.559
1/4												0.812	1.524	2.134	2.692	3.048	3.404	3.860	4.216	4.572	4.724	4.928	5.080	5.232
3/8								1.143	2.007	2.717	3.429	3.987	4.699	5.09	5.867	6.223	6.579	7.035	7.391	7.747	7.899	8.102	8.255	8.407
1/2				0.610	1.524	2.388	3.556	4.318	5.182	5.892	6.604	7.162	7.874	8.484	9.042	9.398	9.754	10.210	10.566	10.922	11.074	11.278	11.430	11.582
5/8	0.635	1.447	2.717	3.785	4.699	5.563	6.731	7.493	8.357	9.067	9.779	10.337	11.049	11.659	12.217	12.573	12.929	13.385	13.741	14.097	14.249	14.453	14.605	14.757
3/4	3.810	4.622	5.892	6.960	7.874	8.738	9.906	10.668	11.532	12.242	12.954	13.512	14.224	14.834	15.392	15.748	16.104	16.560	16.916	17.272	17.424	17.628	17.780	17.932
7/8	6.985	7.797	9.067	10.135	11.049	11.913	13.081	13.843	14.707	15.417	16.129	16.687	17.399	18.009	18.567	18.923	19.279	19.735	20.091	20.447	20.599	20.803	20.955	21.107
1	10.160	10.972	12.242	13.310	14.224	15.088	16.256	17.018	17.882	18.592	19.304	19.862	20.574	21.184	21.742	22.098	22.454	22.910	23.266	23.622	23.774	23.978	24.130	24.282
1.1/4	16.510	17.322	18.592	19.660	20.574	21.438	22.606	23.368	24.232	24.942	25.654	26.212	26.924	27.534	28.092	28.448	28.804	29.260	29.616	29.972	30.124	30.328	30.480	30.632
1.1/2	22.860	23.672	24.942	26.010	26.924	27.788	28.956	29.718	30.582	31.292	32.004	32.562	33.274	33.884	34.442	34.798	35.154	35.610	35.966	36.322	36.474	36.678	36.830	36.982
1.3/4	29.210	30.022	31.292	32.360	33.274	34.138	35.306	36.068	36.932	37.642	38.354	38.912	39.624	40.234	40.792	41.148	41.504	41.960	42.316	42.672	42.824	43.028	43.180	43.332
2	35.560	36.372	37.642	38.710	39.624	40.488	41.656	42.418	43.282	43.992	44.704	45.262	45.974	46.584	47.142	47.498	47.854	48.310	48.666	49.022	49.174	49.378	49.530	49.682
2.1/4	41.910	42.722	43.992	45.060	45.974	46.838	48.006	48.768	49.632	50.342	51.054	51.612	52.324	52.934	53.492	53.848	54.204	54.660						
2.1/2	48.260	49.072	50.342	51.410	52.324	53.188	54.356	55.118	55.982	56.692	57.404	57.962	58.674	59.284	59.842	60.198	60.554	61.010						
2.3/4	54.610	55.422	56.692	57.760	58.674	59.538	60.706	61.468	62.332	63.042	63.754	64.312	65.024	65.634	66.192	66.548	66.904	67.360						
3	60.960	61.772	63.042	64.110	65.024	65.888	67.056	67.818	68.682	69.392	70.104	70.662	71.374	71.984	72.542	72.898	73.254	73.710						



## **TRISTAR INTERNATIONAL**

113/S-2 Vedant Commercial Complex,  
Vartak Nagar, Thane - 400 606 (India )  
Tel. : 91-22-2585 3107 / 2585 6624  
Fax : 91-22-2585 3993  
E-mail : [enquiries@tristarindia.com](mailto:enquiries@tristarindia.com)  
Website : [www.tristarindia.com](http://www.tristarindia.com)